

UNIFIX

CAISSE DE L'ESTAGE UNIFIX B

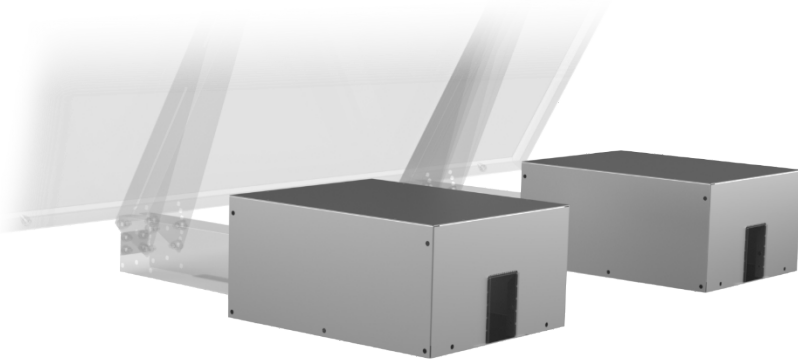

- FR** Caisse de lestage pour Unifix B p.2-7
- EN** Ballast box for Unifix B p.8-13
- ES** Caja de lastre para Unifix B p.14-19
- IT** Cassa di zavorra per Unifix B *www.uniteck.fr*

Cher client, nous vous remercions pour votre achat de l'un de nos produits Uniteck. Veuillez lire avec attention toutes les instructions avant d'utiliser le produit.

DESCRIPTION

La caisse lestage UNIFIX B a été conçue pour les support UNIFIX 300 B / 500 B / 600 B.

Chaque caisse de lestage possède un volume de 34L, soit un poids équivalent de 57,5 kg de sable par caisse et de 115kg par support.

Elle peuvent être remplies de sable, de gravier, de béton...

Une fois montée, la caisse de lestage permet une inclinaison de 20° à 60° de votre support Unifix.

RECOMMANDATIONS

- Montez le support Unifix uniquement sur des surfaces présentant une portance suffisante. Tenez compte de la charge supplémentaire avec panneau.
- Pour éviter que de grandes quantités de neige ne s'accumulent derrière le capteur, installez en amont des grilles d'arrêt appropriées.
- La disposition des capteurs influence vos performances électriques. Choisissez l'inclinaison et l'orientation la plus optimale en fonction de votre environnement. Évitez les zones d'ombre ou que certains objets ne soient source d'ombre (ex. arbre).

CONSIGNES DE SÉCURITÉ

- Prenez les mesures appropriées pour prévenir les accidents pendant vos travaux de montage.
- Si le support et le matériel de montage sont exposés aux rayons du soleil pendant une longue période, il y a un risque de brûlure. Protégez-vous.
- À la fin des travaux, vérifiez que vos supports et panneaux soient bien fixés.







Certains éléments peuvent présenter des rebords coupants. Afin d'éviter tout risque de blessure, veuillez vous munir d'une paire de gants adaptés lors des opérations de manipulation et de montage.

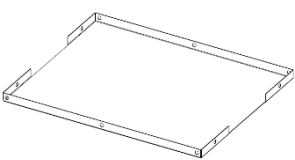
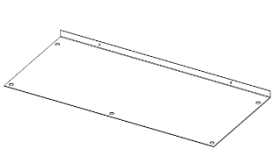
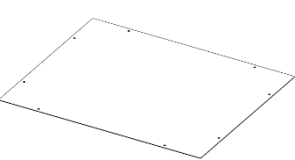
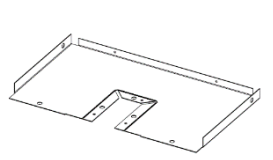

INSTALLATION - FIXATION

Liste des pièces :

	
N°303 X2	N°304 X4
	
N°305 X2	N°306 X4

		
M8x20 X40	D8 X40	M8 X40

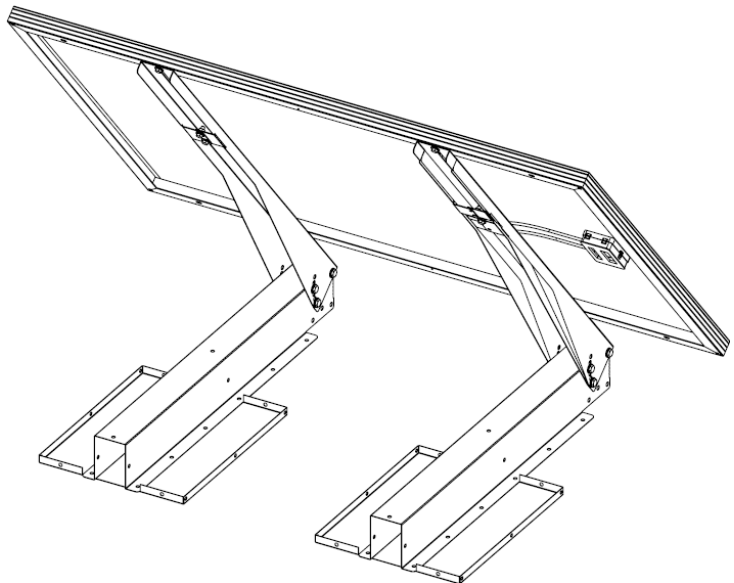
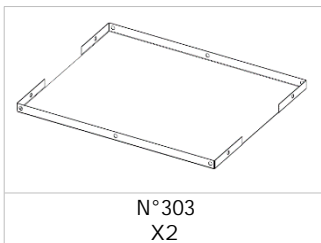

X20

- Positionnez les références N°303 sous votre UNIFIX B.

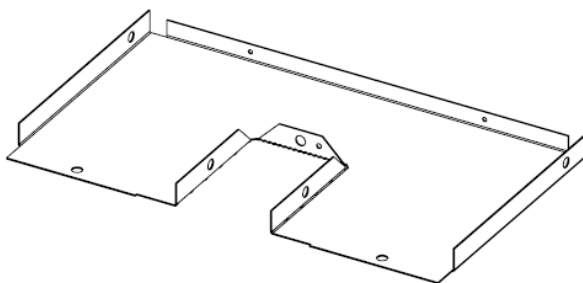
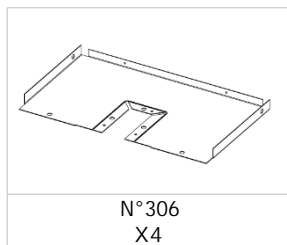

INSTALLATION – FIXATION (SUITE)

- Pliez les N°306.



- Vissez les références N°306 au N°303.

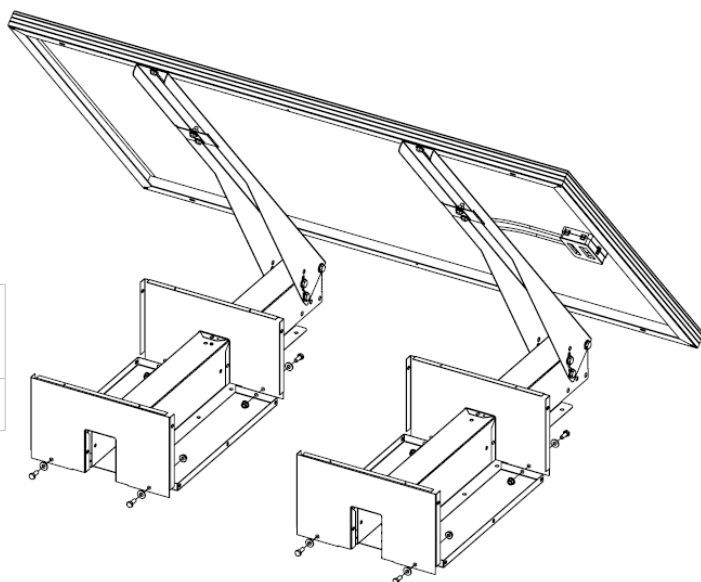
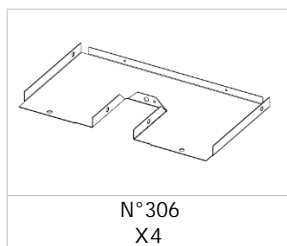

INSTALLATION – FIXATION (SUIITE)

- Fixez le N°306 au support UNIFIX B selon votre version.

Pour les bases comportant le logo « UNITECK »

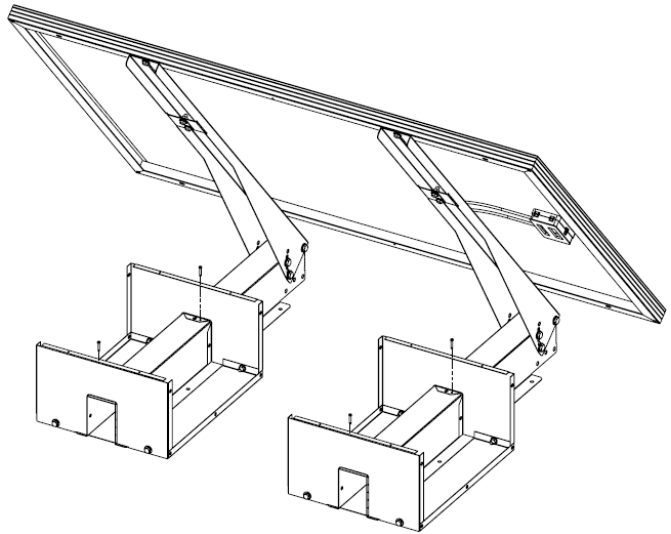

Pour les bases ne comportant pas de logo :

		
M8x20 X12	D8 X12	M8 X12

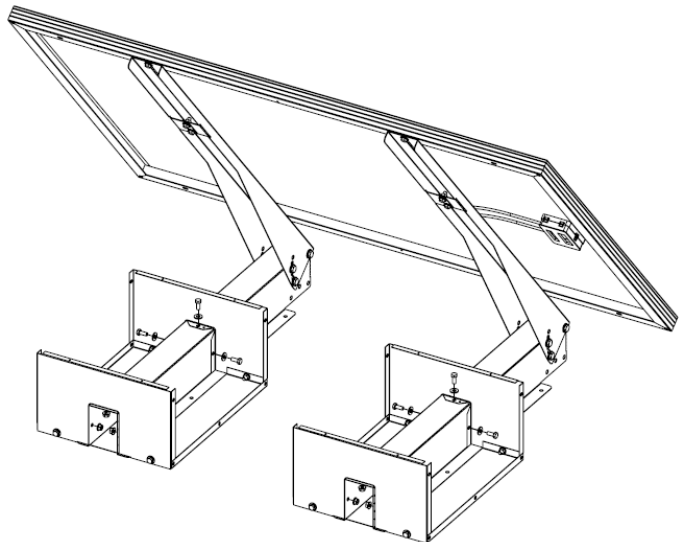

INSTALLATION – FIXATION (SUIVE)

- Pliez les N°304.

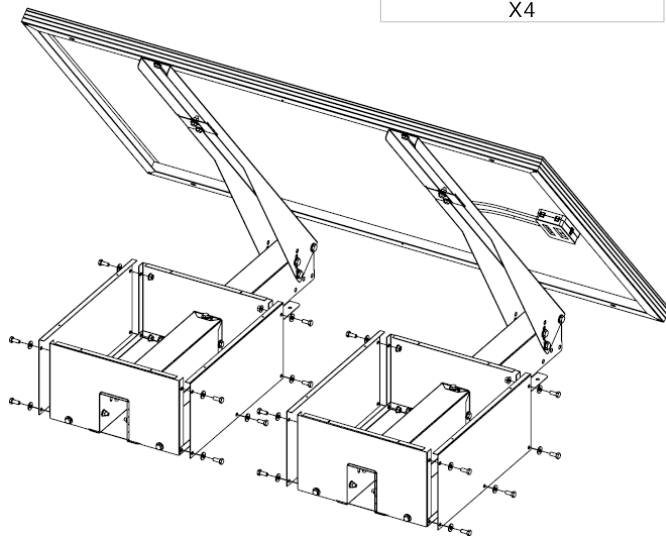
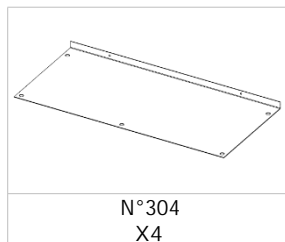

- Remplissez les bacs de sable sec. Tassez le sable.

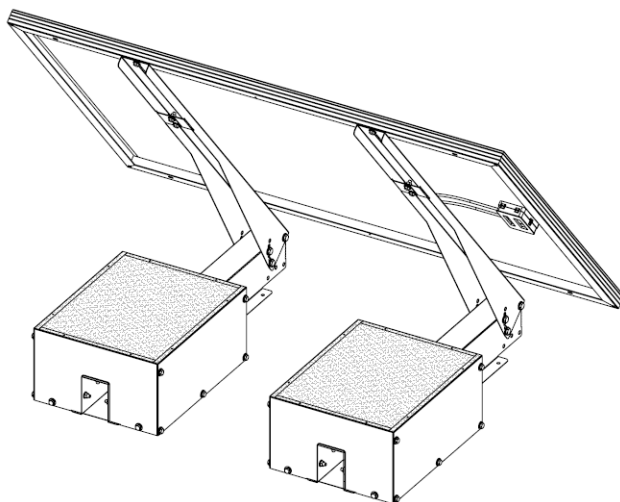

INSTALLATION – FIXATION (SUIITE)

- Vissez les N°305.

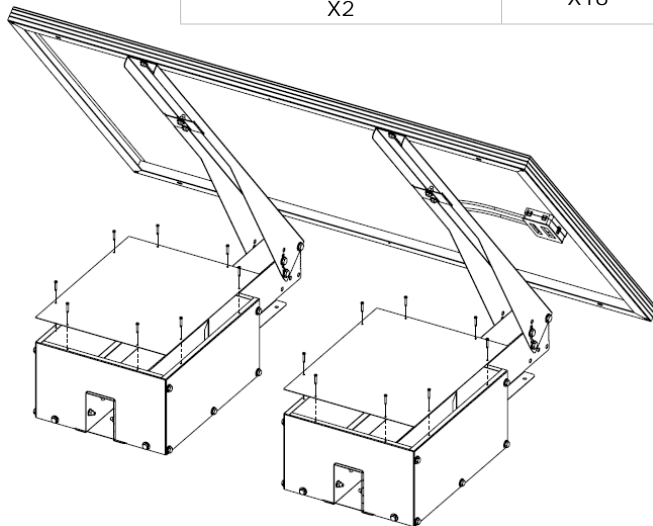
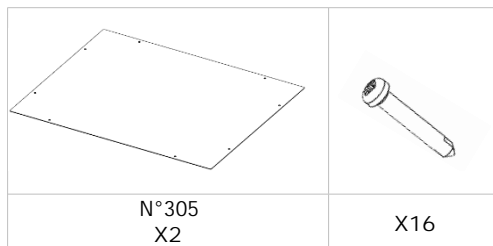

GARANTIE

La garantie couvre tout défaut ou vice de fabrication pendant 2 ans, à compter de la date d'achat (pièces et main d'œuvre).

La garantie ne couvre pas :

- l'usure normale des pièces
- les erreurs de montage

En cas de défauts, retournez le produit à votre distributeur, en y joignant :

- un justificatif d'achat daté (ticket de sortie de caisse, facture...)
- une note explicative du défaut.

Attention : notre SAV n'accepte pas les retours en port dû.

Après la garantie, notre SAV assure les réparations après acceptation d'un devis.

Contact SAV :

Uniteck- 3 Avenue de l'Europe

34310 Montady - France

France mail: sav@uniteck.fr

Dear customer, thank you for purchasing one of our Uniteck products. Please read all the instructions carefully before using the product.

DESCRIPTION

The UNIFIX B ballast box has been designed for UNIFIX 300 B / 500 B / 600 B supports.

Each ballast box has a volume of 34L, i.e. an equivalent weight of 57.5kg of sand per box and 115kg per brackets.

They can be filled with sand, gravel, concrete, etc

Once assembled, the ballast box allows your Unifix support to be tilted from 20° to 60°.

RECOMMANDATIONS

- Only mount Unifix on surfaces with sufficient load-bearing capacity. Bear in mind the additional panel load.
- To prevent large quantities of snow from accumulating behind the panel, install suitable snow guards upstream.
- The arrangement of the panel influences your electrical performance. Choose the best inclination and orientation for your environment. Avoid shady areas or objects that may cast shadows (e.g. trees).

SAFETY INSTRUCTIONS

- Take the appropriate measures to prevent accidents during your mounting steps.
- If the brackets and the mounting tools are exposed to sunlight for a long period, there is a risk of getting burnt. Make sure to protect yourself accordingly.
- When finished, check and make sure that all of your brackets and panels are fixed properly.



Some parts may be sharp. In order to avoid any injury, please wear an adapted pair of gloves while handling and assembly operations.



INSTALLATION – FIXING

List of parts :

N°303 X2	N°304 X4
N°305 X2	N°306 X4

M8x20 X40	D8 X40	M8 X40

X20

- Position reference no. 303 under your UNIFIX B.

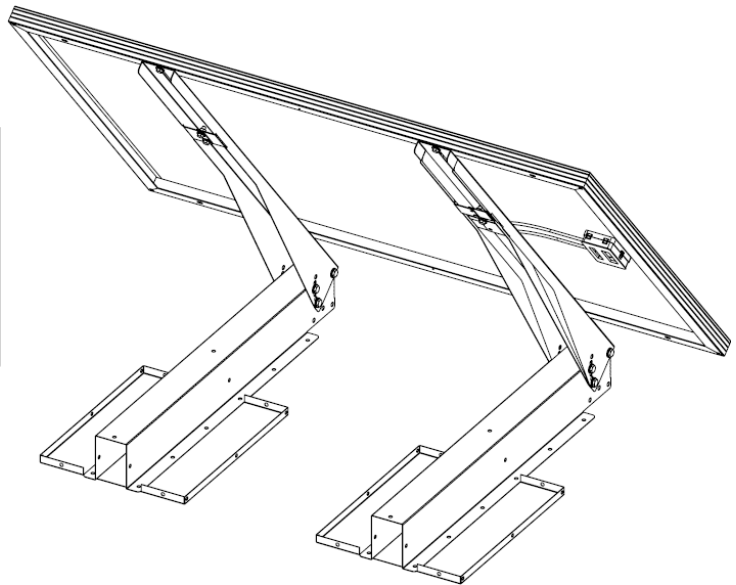
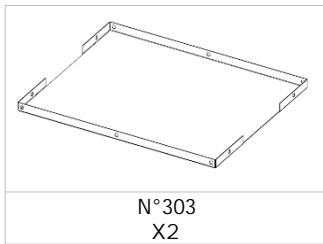

INSTALLATION – FIXING (CONTINUATION)

- Fold N°306.

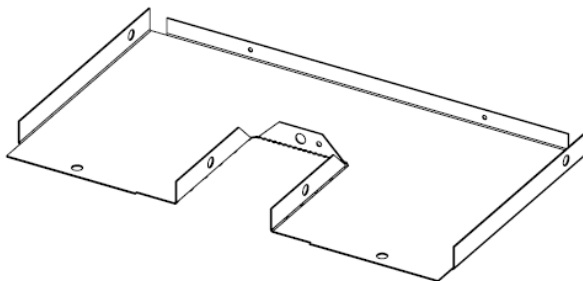
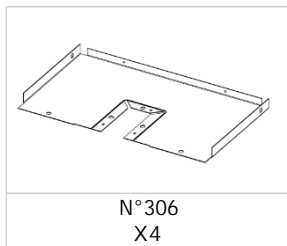

- Screw part numbers N°306 to N°303.

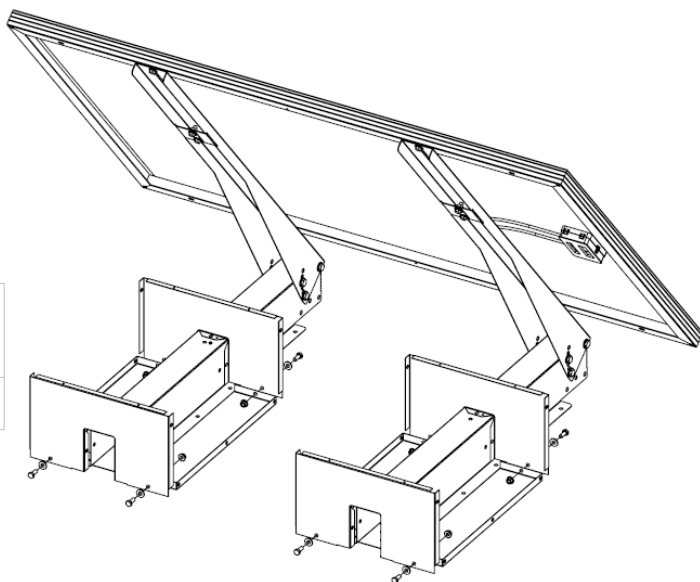
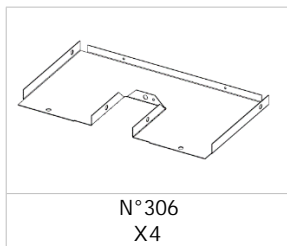

INSTALLATION – FIXING (CONTINUATION)

- Fix the N°306 to the UNIFIX B bracket according to your version.

For bases featuring the « UNITECK » :

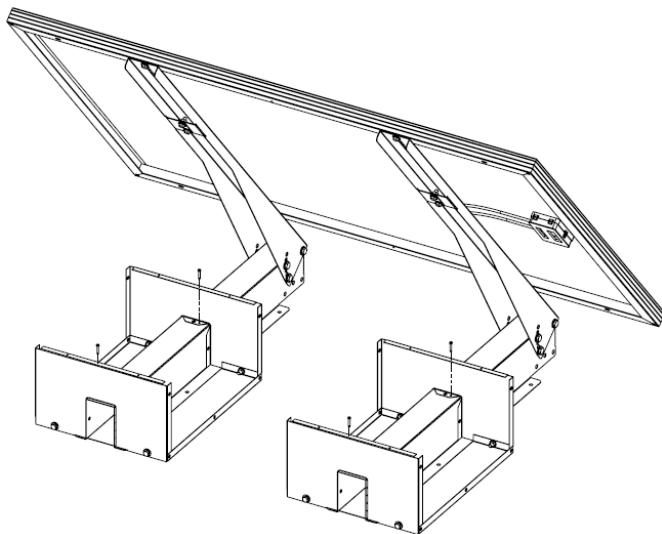

For bases without logo :

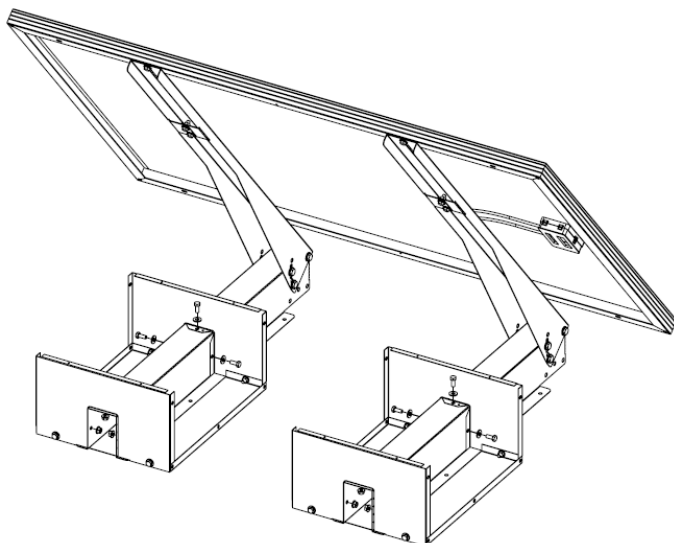

INSTALLATION – FIXING (CONTINUATION)

- Fold N°304.

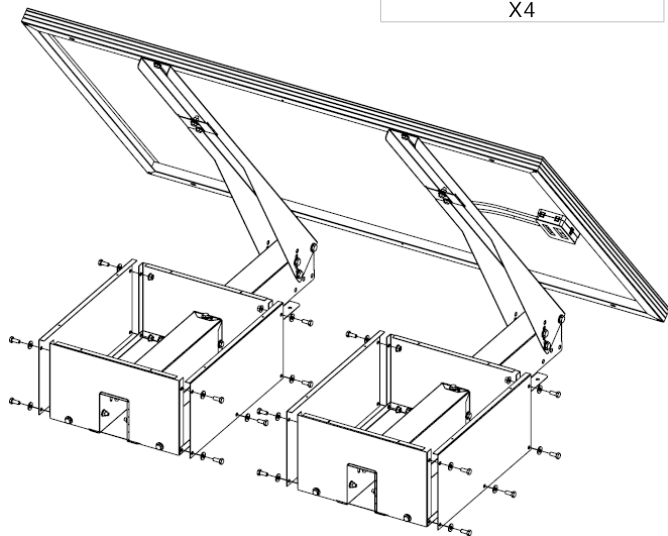
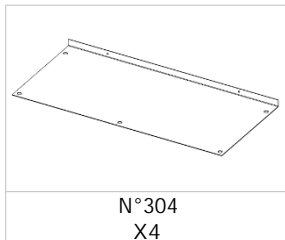

- Fill the box with dry sand. Pack the sand.

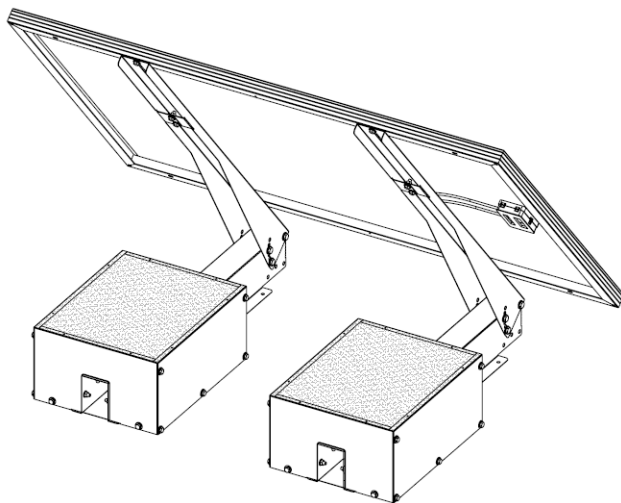

INSTALLATION – FIXING (CONTINUATION)

- Screw on N°305.

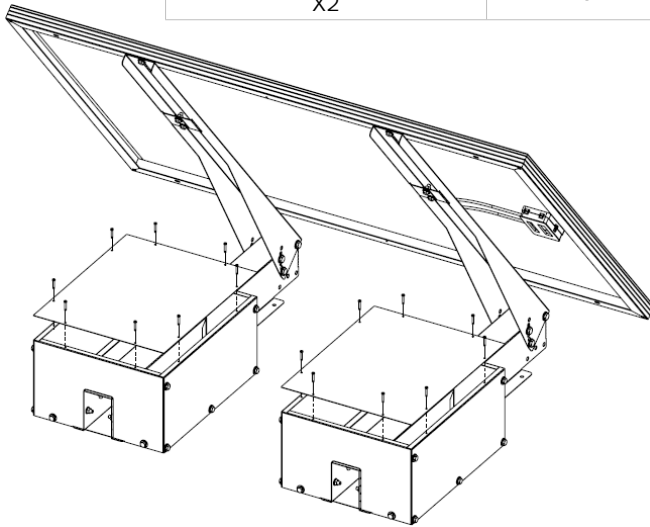
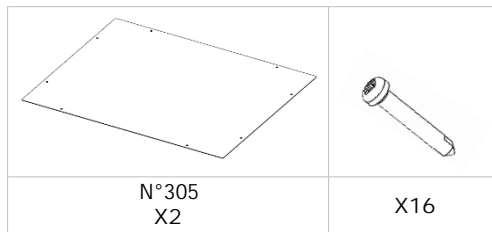

WARRANTY

The warranty covers any manufacturing defect or fault for 2 years from the date of purchase (pieces and labour).

The warranty does not cover :

- Normal wear and tear of parts.
- Errors in installation.

In the event of defects, return the product to your distributor by attaching:

- Proof of purchase date (receipt, invoice...)
- A note explaining the defect.

Caution : Our after-sales service does not accept returns with postage due.

After the warranty period, our after-sales service will ensure repair of your product once a provided quotation has been accepted.

After-sales service contact :
 Uniteck- Avenue de l'Europe
 34310 Montady - France
 France mail: sav@uniteck.fr

Estimado cliente, gracias por comprar nuestro producto Uniteck. Por favor lea con cuidado todas las instrucciones antes de usar el producto.

DESCRIPCIÓN

La caja de lastre UNIFIX B fue diseñada para los soportes UNIFIX 300 B / 500 B / 600 B.

Cada caja de lastre tiene un volumen de 34L, o sea 57.5 kg de arena por cada caja.

Se pueden rellenar con arena, grava, hormigón.

Una vez ensamblada, la caja de lastre permite una inclinación de 20° hasta 60°.

RECOMENDACIONES

- Monte el soporte Unifix solo en superficies con suficiente capacidad de carga. Tenga en cuenta la carga adicional con panel.
- Para evitar que grandes cantidades de nieve se acumule sobre o detrás de las células, instale antes rejillas paranieve adecuadas.
- La disposición de las células influye en su rendimiento eléctrico. Elija la inclinación y orientación más óptimas según su entorno. Evite las zonas con sombra o que ciertos objetos sean fuente de sombra (por ejemplo, un árbol).

CONSIGNAS DE SEGURIDAD

- Tome las medidas adecuadas para prevenir los accidentes durante sus fases de montaje.
- La exposición del soporte y del material de montaje a los rayos del sol durante un largo tiempo puede provocar quemaduras. Protéjase.
- Cuando acabe su montaje, asegúrese de que sus soportes y paneles estén bien fijados.







Algunas partes del soporte pueden ser afilados. Para evitar cualquier riesgo de herida, lleve guantes de protección adaptados durante las operaciones de transporte y de montaje.

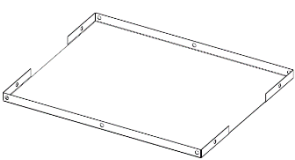
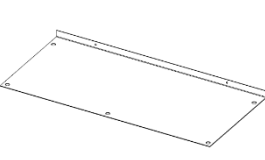
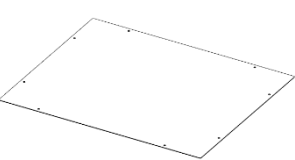
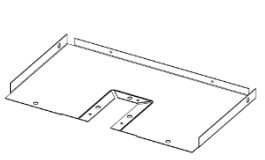

INSTALACIÓN - FIJACIÓN

Lista de piezas :

	
N°303 X2	N°304 X4
	
N°305 X2	N°306 X4

		
M8x20 X40	D8 X40	M8 X40

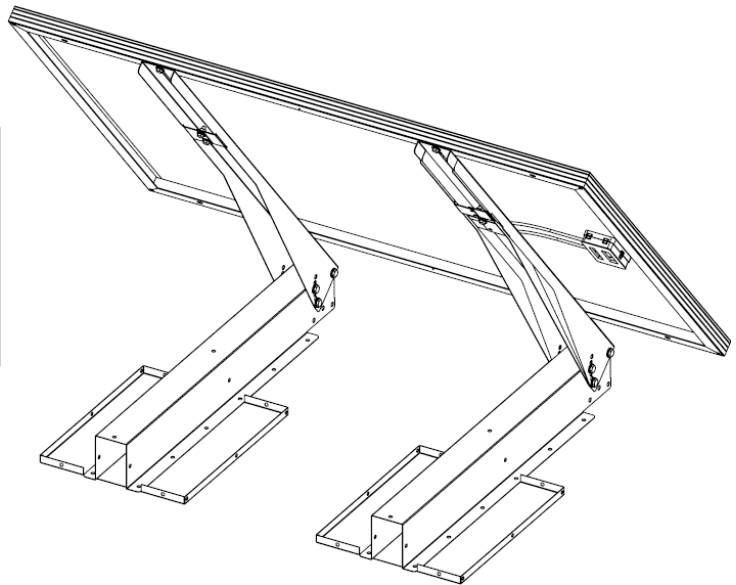
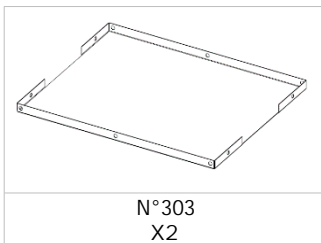

X20

- Coloque las referencias N°303 bajo su UNIFIX B.

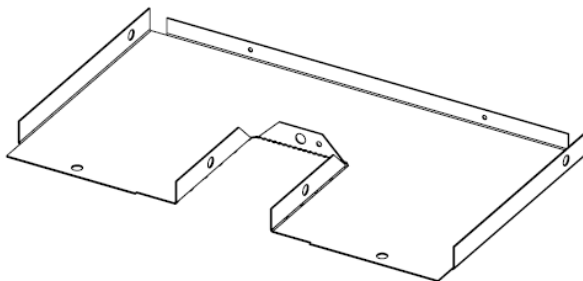
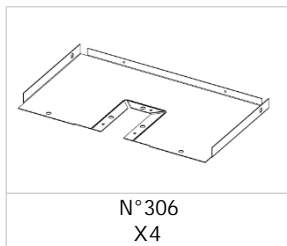

INSTALACIÓN - FIJACIÓN (CONTINUACIÓN)

- Doble los N°306.



- Atornille las referencias N°306 au N°303.

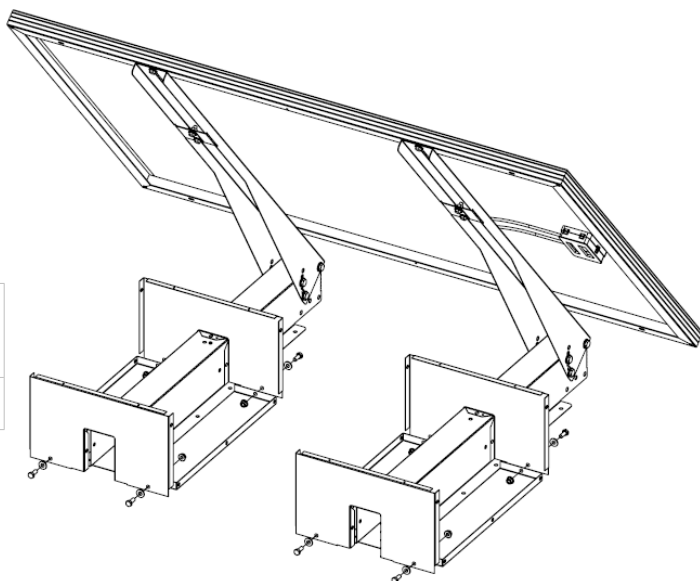
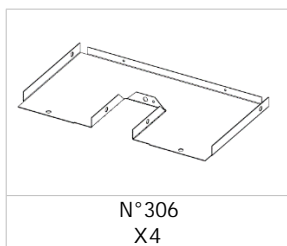

		
M8x20 X8	D8 X8	M8 X8



INSTALACIÓN - FIJACIÓN (CONTINUACIÓN)

- Fije el N°306 al soporte UNIFIX B según su versión.

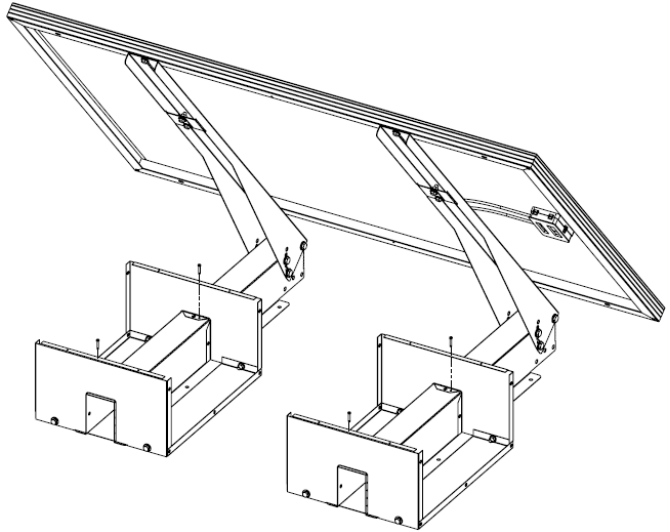
Para las bases con el logotipo « UNITECK » :



Para las bases sin logotipo :

		
M8x20 X12	D8 X12	M8 X12

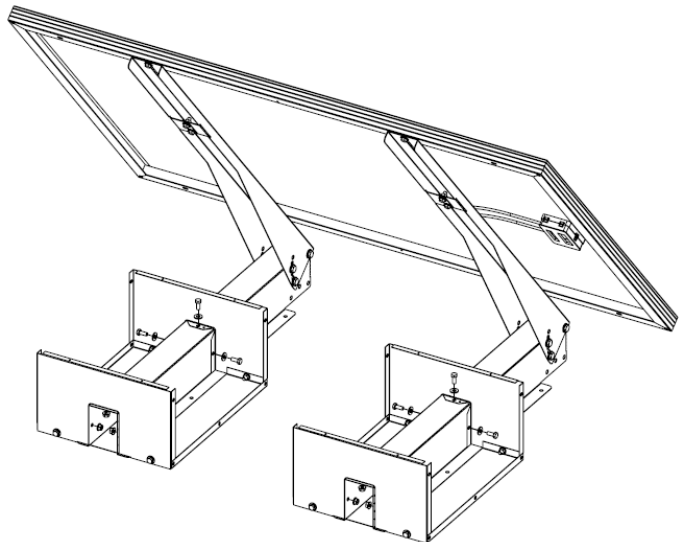

INSTALACIÓN - FIJACIÓN (CONTINUACIÓN)

- Doble las N°304.

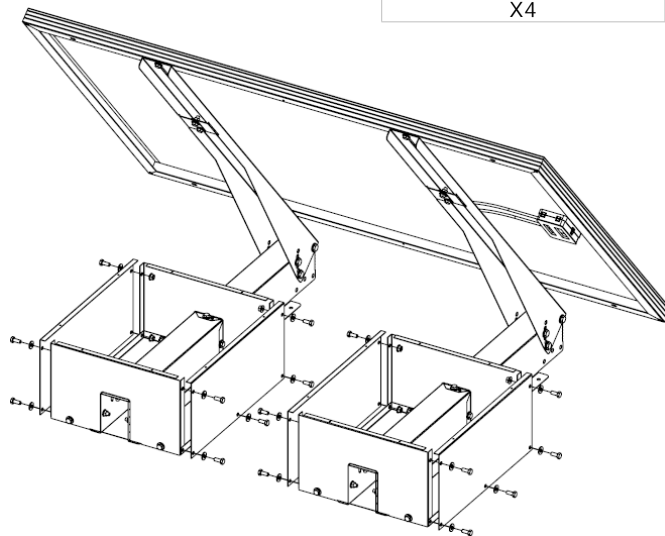
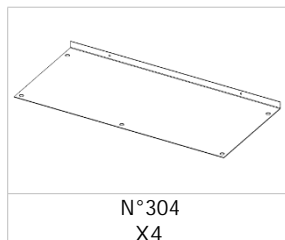

- Rellene los contenedores con arena seca. Apisone la arena.

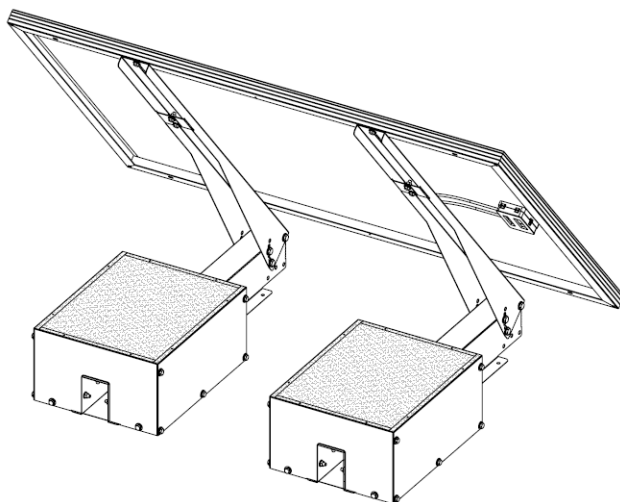

INSTALACIÓN - FIJACIÓN (CONTINUACIÓN)

- Apriete los N°305.

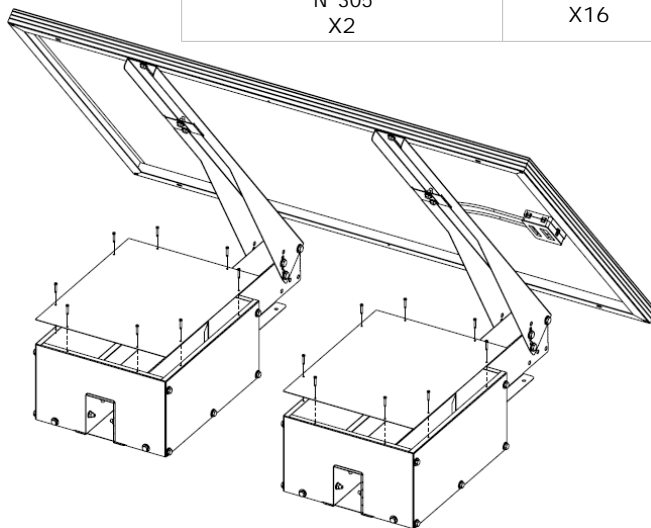
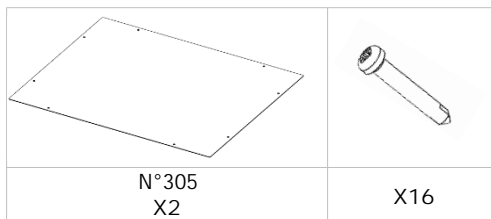

GARANTÍA

La garantía cubre todo defecto o vicio de fabricación durante 2 años, a partir de la fecha de compra (piezas y mano de obra).

La garantía no cubre:

- El desgaste normal de las piezas
- Incidente debido a un mal uso, caída, desmontaje o toda otra avería debida al transporte.

En caso de avería, devuelva el producto a su distribuidor con:

- Un justificativo de compra con fecha (tiquete de caja central, factura...)
- Una nota explicativa de la avería.

Cuidado: nuestro Servicio Postventa no acepta devoluciones con portes debidos.

Después del plazo de garantía, nuestro Servicio Postventa asegura las reparaciones después de aceptación de un presupuesto.

Contacto SPV :

UNITECK SARL
3 Avenue de l'Europe
34310 Montady - FRANCE
Mail : sav@uniteck.fr